

INDUSTRIAL THERMOMETER

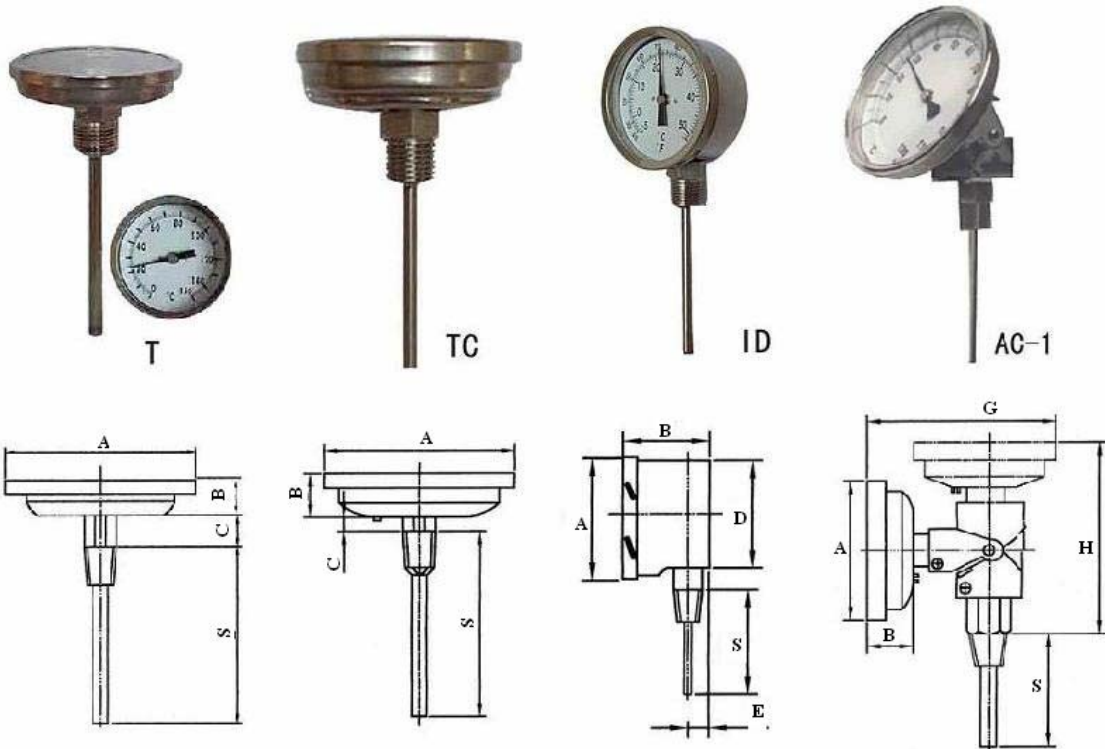

ITEM	MODEL	DIAL SIZE	A	B	C	D	E	H	G	S	CON.	HEX
T	T200-1	2"	54.5	10.0	9.0	-	-	-	-	2"	1/4"NPT	11
TC	T300C	3"	83.5	22.0	10.0	-	-	-	-	4"	1/2"NPT	21
	T400C	4"	110.0	23.0	10.0	-	-	-	-	6"	1/2"NPT	21
ID	I300ID	3"	77.0	43.5	-	68.7	12.0	-	-	2"/4"	1/2"NPT	21
	I400ID	4"	109.0	47.0	-	100.5	12.0	-	-	6"	1/2"NPT	21
AC-1	A400C-1	4"	110.0	23.0	-	-	-	98.0	117.0	6"/12"	1/2"NPT	21

Specification

- Case: AISI 304 SS
- Lens: Glass
- Bezel: AISI 304 SS, hermetically sealed
- Movement: Bi-Metallic Coil
- Stem: AISI 304 SS, Diameter 6.35 mm
- Accuracy: +/- 1.5% Full Scale